

(No Model.)

3 Sheets—Sheet 1.

J. SWAN.
MACHINE FOR GROOVING BIT BLANKS.

No. 381,092.

Patented Apr. 10, 1888.

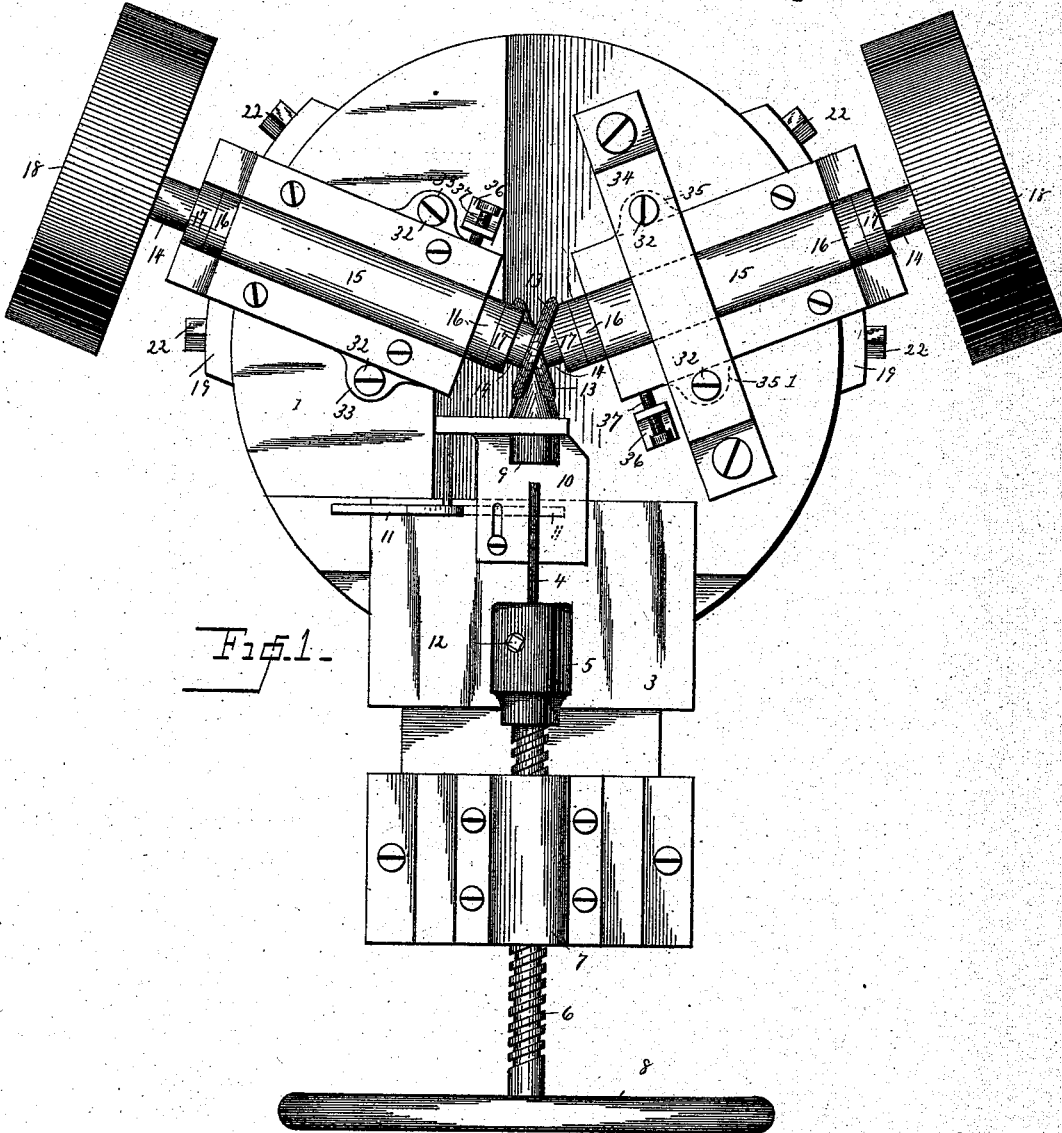

Fig. 1.

WITNESSES.
W. A. Gortland.
B. E. Lee.

INVENTOR:
James Swan.
By
A. M. Wooster,
att'y.

(No Model.)

3 Sheets—Sheet 2.

J. SWAN.
MACHINE FOR GROOVING BIT BLANKS.

No. 381,092.

Patented Apr. 10, 1888.

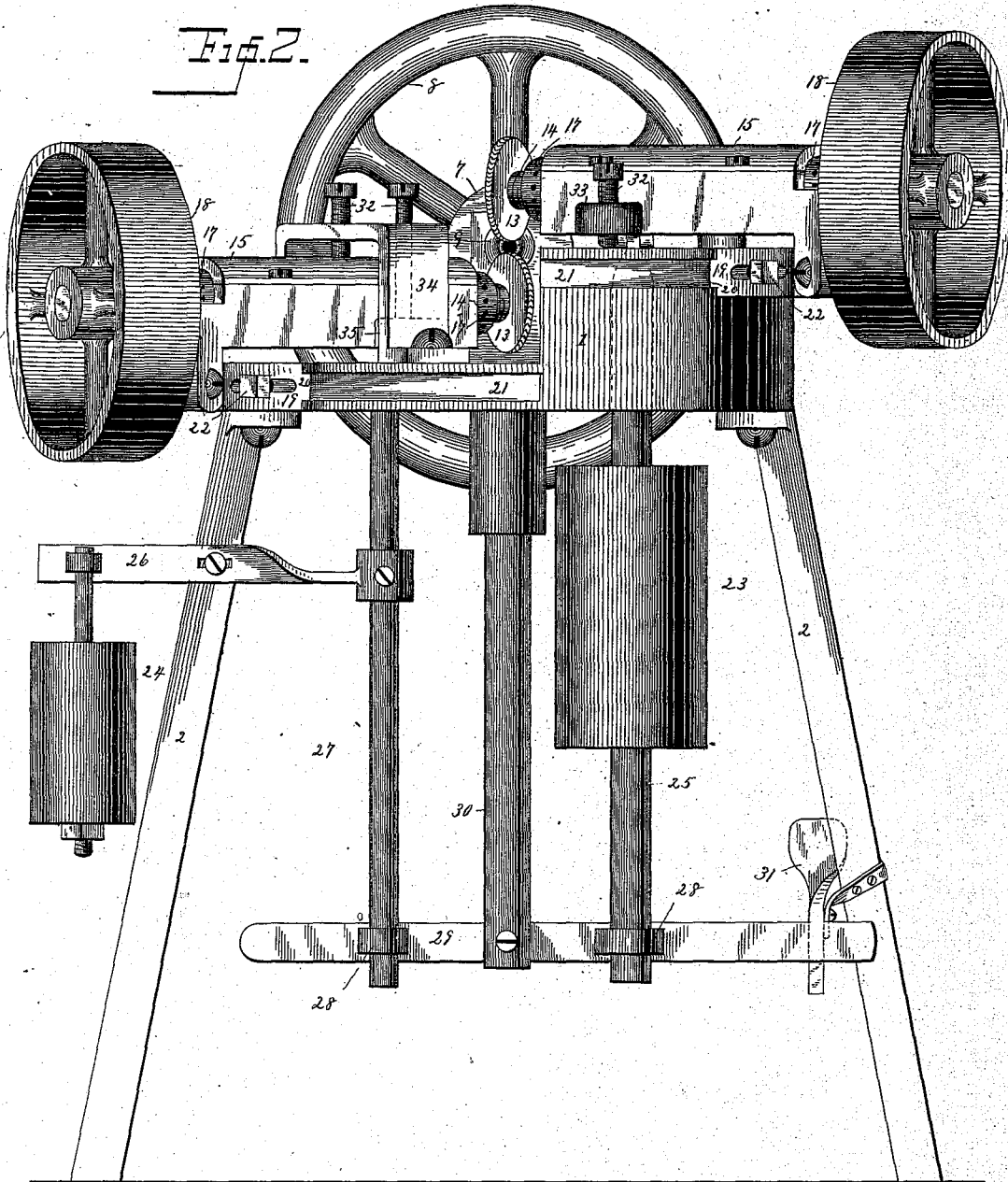

WITNESSES.
W. H. Goulland,
R. E. Lee.

INVENTOR.
James Swan.
By A. M. Wooster,
Atty.

(No Model.)

3 Sheets—Sheet 3.

J. SWAN.
MACHINE FOR GROOVING BIT BLANKS.

No. 381,092.

Patented Apr. 10, 1888.

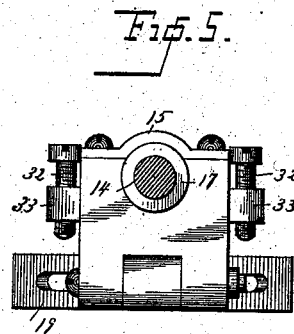
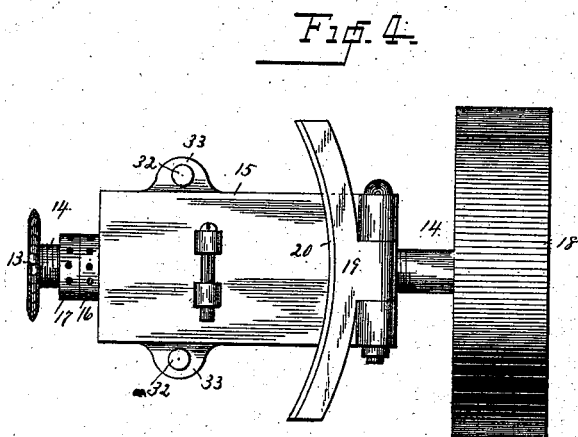
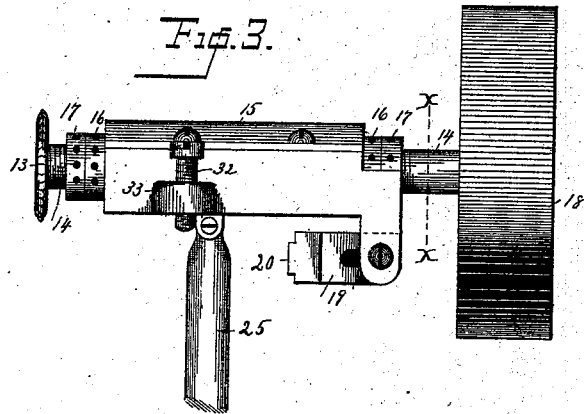

WITNESSES.
W. H. Courtland.
B. C. Lee.

INVENTOR.
James Swan.
By J. M. Wooster
att'y.

UNITED STATES PATENT OFFICE.

JAMES SWAN, OF SEYMOUR, CONNECTICUT.

MACHINE FOR GROOVING BIT-BLANKS.

SPECIFICATION forming part of Letters Patent No. 381,092, dated April 10, 1888.

Application filed January 26, 1888. Serial No. 261,973. (No model.)

To all whom it may concern:

Be it known that I, JAMES SWAN, a citizen of the United States, residing at Seymour, in the county of New Haven and State of Connecticut, have invented certain new and useful Improvements in Machines for Grooving Bit-Blanks; and I do hereby declare the following to be a full, clear, and exact description of the invention, such as will enable others skilled in the art to which it appertains to make and use the same.

My invention has for its object to produce a machine of this class which shall be simple in construction and adjustment, durable, and which will produce the best of work at a greatly-increased rate of speed.

With these ends in view I have devised the novel construction of which the following description, in connection with the accompanying drawings, is a specification, numbers being used to denote the several parts.

Figure 1 is a plan view of the machine complete; Fig. 2, a rear elevation thereof; Fig. 3, an elevation of a cutter and hinged journal-box detached; Fig. 4, an inverted plan view corresponding with Fig. 3; Fig. 5, a cross-section on the line *x x* in Fig. 3, looking toward the left; and Fig. 6 is a view of a double-ended blank as grooved by the machine.

1 denotes the bed of the machine, a portion of which is raised above the other portion, forming upper and lower planes, the purpose of which will presently be clearly understood, and 2 denotes the legs by which it is supported.

The bed is preferably made circular in form, as shown in the drawings, and is provided at its front end with an extension, 3, which may be made integral therewith or cast separately and attached thereto.

4 denotes the blank to be operated upon, which is carried by a chuck, 5, at the end of a screw, 6, passing through a stationary nut or box, 7, at the forward end of the extension. In the present instance I have shown the blanks as fed forward by a hand-wheel, 8, although in practice I contemplate making the feed automatic. As the blank is fed forward it passes into a guide, 9, upon a plate, 10, which is adjustably and detachably secured to extension 3, as shown.

11 is a stop carried by plate 10, which is

adapted to swing over toward the right, as shown in dotted lines in Fig. 1, to limit the forward movement of the chuck when the blank has been thrown far enough forward so that the cutters shall have made grooves of the required length therein.

The rear end of the guide is made coneshaped and is cut away obliquely, as indicated in Fig. 2, to enable the cutters to operate upon the blank. It should be understood that the blank fits closely enough in the guide so as to be held against any lateral movement during the operation of the cutters. A different-sized guide is of course used for each-sized blank that is operated upon. Any lathe-chuck of suitable construction may be used, it being simply required that the chuck shall act quickly, preferably by a screw, 12, and shall hold the blank firmly without marring it. In practice one end of the blank is fed forward to the cutters and operated upon, then the grooved end is inserted in the chuck and the opposite end grooved. The blank is then cut in two, and the other processes of forming the completed auger, bit, or gimlet are proceeded with.

13 denotes the cutters, which are carried by shafts 14, journaled in boxes 15.

16 and 17 denote, respectively, nuts and check-nuts on shafts 14, whereby the desired endwise adjustment is given to said shafts, it being of course understood that the cutters are changed for each size of blank and that the adjustment of said cutters must be absolutely accurate.

18 denotes belt-pulleys at the outer ends of shafts 14, from which belts (not shown) run to a suitably-arranged shaft or countershaft. As the cutters operate upon opposite sides of the blank, it will of course be understood that one of the belts must be crossed, so that the cutters will rotate in opposite directions. In order that I may cause the cutters to cut the grooves at any desired pitch, and in order that they may be thrown from their operative position the instant the grooving operation is completed, I hinge the outer ends of the boxes 15, in which the cutter-shafts are journaled, to blocks 19, having tongues 20, adapted to slide in grooves 21 at the opposite edges of the bed, as clearly shown in Fig. 2.

22 denotes bolts passing through slots in the blocks and engaging the solid metal of the bed. When it is desired to adjust the cutters to change the pitch of the grooves, the two bolts which pass through each block are loosened, the blocks adjusted, and the bolts are then tightened up again. In order to hold the cutters in operative position in use, I preferably employ weights 23 and 24. Weight 23 is carried by a rod, 25, pivoted to the lower side of the upper cutter-shaft box, its action being simply to draw the upper cutter down to its operative position and hold it there. Weight 24 is suspended from the outer end of a lever, 26, which is pivoted to one of the legs, and its inner end connected to a rod, 27, the upper end of which bears against the under side of the lower cutter-shaft box acting to raise said lower cutter to its operative position and hold it there. The lower ends of rods 25 and 27 are connected by means of eyebolts 28 to a lever, 29, pivoted midway between them to a rigid rod, 30, depending from the bed of the machine.

31 denotes a feed-lever pivoted to a bracket secured to one of the legs. The forward end of this lever bears upon the underside of lever 29, so that when the foot-lever is pressed down its forward end is raised, raising one end of lever 29, which carries weight 23 upward, and by means of rod 25 raises the upper cutter-shaft box and carries the cutter out of operative position. It is of course apparent that the opposite end of lever 29 will be moved downward, which will draw rod 27 downward against the power of weight 24 and will allow the lower cutter-shaft box to drop downward slightly, carrying the lower cutter out of operative position. The depth of the groove cut in the blank is regulated by means of set-screws 32, there being two set-screws provided for each cutter-shaft box, as clearly shown in Fig. 1. The set-screws for adjusting the upper cutter-shaft and cutter pass through lugs 33 upon the box and their points bear against the bed of the machine, thereby limiting the downward movement of the box, shaft, and cutter. The set-screws for adjusting the lower cutter pass through a bracket, 34, and their ends bear against lugs 35 upon the sides of the lower cutter-shaft box.

36 denotes plates upon the bed, each of which is provided with a set-screw, 37, the point of which bears against one of the cutter-shaft boxes and acts to overcome any tendency of the boxes to spring out of position in use, and at the same time preventing any strain upon the hinged connections of the boxes.

In use the blank is placed in the chuck, as already described, and is fed forward through the guide to the cutters either automatically or by hand, as shown. The instant the chuck comes in contact with stop 11 the operator places his foot on foot-lever 31 and throws both of the cutters out of operative position, as already described. The chuck and blank are then withdrawn, the blank is changed end for

end in the chuck, or a new blank is inserted, and the chuck is ready to be fed forward again, as before. The instant the operator's foot is removed from foot-lever 31 the cutters drop back to their operative position. It will be seen that no clutch or belt-shifting mechanism is required, there being no necessity for stopping the cutters until a change is made in the class of work.

It will of course be understood that the various details of construction may be greatly changed without departing in the slightest from the principles of my invention.

I claim—

1. The combination, with a chuck for carrying the blank and a guide to receive the blank, of grooving-cutters on opposite sides of the guide, shafts therefor, and hinged boxes for said shafts which permit the cutters to be thrown out of operative position without stopping their movement.

2. In a grooving-machine, the combination, with a guide for the blank, of cutters on opposite sides thereof and arranged obliquely thereto, shafts for said cutters, and hinged boxes for the shafts.

3. A machine for grooving bit-blanks, consisting, essentially, of a chuck for carrying the blanks, having axial rotation as it moves forward, a guide to steady the blanks, cutters which groove the blanks, and hinged journal-boxes for said cutters, which permit them to be moved into and out of operative position.

4. In a machine for grooving bit-blanks, the combination, with the cutters and shafts therefor, of boxes in which said shafts are journaled, and sliding blocks to which said boxes are hinged, whereby the pitch at which the grooves are cut may be regulated.

5. A circular table having grooves in its opposite edges and blocks adjustable in said grooves, in combination with grooving-cutters, shafts therefor, and boxes for said shafts, which are hinged to said blocks, as and for the purpose set forth.

6. The combination, with the cutters, their shafts, and hinged boxes therefor, of weights acting to hold the cutters in operative position, and rods, levers, and a foot-lever, substantially as described, whereby the power of the weights may be overcome and the cutters thrown out of operative position.

7. The bed, extension, chuck, and cutters, substantially as described, in combination with an adjustable guide secured to the extension and a stop carried by the guide, which limits the forward movement of the chuck, as and for the purpose set forth.

8. The combination, with the chuck, guide, and cutters, of hinged boxes in which the cutter-shafts are journaled, means, substantially as described, for holding the cutters in operative position, and set-screws 32, whereby the depth of the cut may be regulated.

9. The circular bed having upper and lower planes and grooves 19 in the edges thereof, in combination with upper and lower cutters,

shafts and boxes therefor, and blocks adjustable in said grooves, to which the boxes are hinged.

5 10. The bed having upper and lower planes and grooves in the edges thereof and blocks adjustable in said grooves, in combination with the upper and lower cutters, shafts, and boxes therefor hinged to said blocks, lugs upon the upper box, and set-screws passing through
10 them and engaging the bed to regulate the depth of cut of the upper cutter, and a bracket, 34, having set-screws passing through it and engaging lugs upon the lower box, whereby the depth of cut of the lower cutter is regulated.
15

11. The upper and lower cutters, shafts, and boxes therefor, in combination with a rod and weight hinged to the upper box, a rod con-

trolled by a weight bearing against the lower box, a pivoted lever, 29, to which both rods are pivoted, and a foot-lever adapted to engage lever 29 to raise the rod pivoted to the upper box and lower the rod bearing against the under box, whereby the cutters are thrown
20 out of operative position. 25

12. The bed, sliding blocks, cutters, shafts, and hinged boxes, in combination with plates 36 and screws 37, engaging the boxes to prevent lateral movement of the cutters in use.

In testimony whereof I affix my signature in
30 presence of two witnesses.

JAMES SWAN.

Witnesses:

A. M. WOOSTER,
B. E. LEE.